

ULTRAHEAT[®]T330 ULTRACOLD[®]T330



Technical description

32 22 101 001 a
Date: 07.04.2017
Landis+Gyr GmbH

Outstanding features

Meter for measurement of flow and energy in a heat or cold circuit with water using the ultrasonic principle.

Important properties are:

- Non-wearing due to non-moving parts
- Compact, space-saving design
- Robust all-metal measuring section
- Exceptional robust DuraSurface™
- Easy installation and read out
- Fast and intelligent temperature measuring interval
- Large, easy readable display
- Flow measurement with maximum values
- 2 set days per month for 24 months (parameterizable)
- Battery lifetime up to 11 years
- Integrated communication for remote readout or system connection
- Self-diagnosis

Contents

1	General notes	4
	Other available documents	4
2	Safety information	5
3	Technical data	7
	Dimensions (qp 0,6 – 2,5 m ³ /h)	8
4	Installation	10
	Installation notes	10
	Examples of installation	11
	Installation notes for sensor adapter set (sensors directly immersed)	12
4.1	Installation for cooling metering	12
5	Dimension of electronic unit	13
6	Operating elements	15
6.1	Displaying current meter status	15
	User loop "LOOP 0"	15
	Current values "LOOP 1"	16
	Previous month's values "LOOP 2"	16
	General / Communication "LOOP 3"	17
	Other "LOOP 4"	17
6.2	Monthly values	17
7	Resolution of the display	18
8	Power supply	18
9	Communication	19
	Electronic unit interfaces	19
9.1	M-Bus	19
9.2	Pulse output	19
9.3	Wireless M-Bus	20
	Predefined data telegrams	20
	Data telegram F000 – stationary radio (sending interval 15 min)	20
	Data telegram F001 – mobile data reading (sending interval 20 sec, battery lifetime 6 years)	21
	Data telegram F002 – mobile data reading (sending interval 34 sec, battery lifetime 11 years)	21
10	Error codes	22
11	Order codes (type number key)	23
12	Additional ordering information for wM-Bus	24
13	Pressure loss	25

1 General notes



Note: In the following text, the term meter refers to heat meter and cooling meter, unless they are otherwise differentiated.

The meter is used as a meter for heating or cooling consumption measurement in systems with water.

The meter consists of a volume measurement unit, two fixed temperature sensors and an electronic unit that calculates the energy consumption from the volume and temperature difference.

Other available documents

- Operating and Installation Instructions T330
- Respective module operating and installation instruction
- Illustrated catalogue
- Datasheet

Additional information is available on request.

2 Safety information



The meter may only be used in building service engineering systems and only for the applications described.



The local regulations (installation etc.) must be adhered to.



Adhere to the operating conditions according to the dial plate during use. Non-adherence can cause hazards and the guarantee will expire.



The meter is only suitable for circulating water in heating systems.



The meter is not suitable for drinking water.



Be aware of sharp edges on thread and measuring tube.



The meter is suitable for circulating water in heating systems. Adhere to the AGFW requirements regarding circulating water (FW510).



Do not lift the meter by the electronic unit or by the adapter plate.



Only personnel, trained in the installation and operation of meters in heating and cooling systems, may install and remove the meter.



Only install or remove the meter when the pipes are pressureless.



After installing the meter, check the leak-tightness of the system.



Guarantee and calibration validity will lapse if the calibration relevant security seal is broken.



Only clean the meter from outside with a soft, lightly wetted cloth. Do not use any spirit or cleaning solvent.



As far as disposal is concerned, the meter is a waste electronic appliance in the sense of European Directive 2012/19/EU (WEEE) and it must not be disposed of as domestic waste. The relevant national, legal regulations must be observed as the appliance must be disposed of via the channels provided for this purpose. The local and currently valid legislation must be observed.



The meter contains lithium batteries. Do not dispose of the meter and the batteries with domestic waste. Observe the local stipulations and laws on disposal.



You can return the lithium batteries to the manufacturer for appropriate disposal following use. When shipping please observe legal regulations, in particular, those governing the labelling and packaging of hazardous goods.



Do not open the batteries. Do not bring batteries into contact with water or expose to temperatures above 80 °C.



The meter does not have any lightning protection. Ensure lightning protection by the house installation.

3 Technical data

General

Measuring accuracy	Class 2 or 3 (EN 1434)
Environment class	A (EN 1434) for indoor installation
Mechanical class	M1 / M2 *)
Electromagnetic class	E1 *)
	*) acc. to 2014/32/EU Directive on Measuring Instruments
Ambient humidity	< 93 % relative humidity at 25 °C, without condensation
Max. height	2000 m above sea level
Storage temperature	-20 ... 60 °C

Electronic unit

Ambient temperature	5 ... 55 °C
Housing protection rating	IP 54 acc. to EN 60529
Power supply	Battery for 6 or 11 years
Operation threshold for ΔT	0.2 K
Temperature difference ΔT	3 K ... 80 K
Temperature measurement range	0 ... 180 °C
LCD	7 digit
Optical interface	Standard, EN 62056-21
Communication	Optional
Separability	Always, cable length 1.5 m

Temperature sensor

Type	Pt500 acc. to EN 60751, not detachable
Connection type	Pt500, 2 wire technology
Cable length	1,5 m
Construction type	Bulb sensor \varnothing 5.2 x 45 mm, DS direct short, M10 x 27.5 mm
Temperature range	0 ... 105 °C

Volume measurement unit

Protection class	IP 54 acc. to EN 60529, optional IP 65
Mounting place	Hot side / cold side
Installation position	Any, horizontal or vertical
Flow straightening	None
Measuring range	1:100
Temperature range	5 ... 105 °C
Maximum overload	qs = 2 x qp, permanent
Nominal pressure	PN16 (1.6 MPa; PS16) PN25 (2.5 MPa; PS25)

qp	Overall length and connection		
m³/h			
0.6	110 mm (3/4 ")		190 mm (1 ")
1.5	110 mm (3/4 ")	130 mm (1 ")	190 mm (1 ")
2.5		130 mm (1 ")	190 mm (1 ")

Nominal flowrate q_p	Overall length	Connection	Maximum flowrate q_s	Minimum flowrate q_i	Response threshold (variable)	Pressure loss at q_p	Kv-value at Δp 1 bar	Kv-value at Δp 100 mbar	Pack size (LxBxH)	Weight
m^3/h	mm	G	m^3/h	l/h	l/h	mbar	m^3/h	m^3/h	cm	kg
0.6	110	G 3/4	1.2	6	1.2	150	1.5	0.5	15.5 x 13.5 x 12.0	0.8
0.6	190	G1	1.2	6	1.2	150	1.5	0.5	22.5 x 18.5 x 11.3	1.1
1.5	110	G 3/4	3	15	3	150	3.9	1.2	15.5 x 13.5 x 12.0	0.8
1.5	130	G1	3	15	3	160	3.8	1.2	15.5 x 13.5 x 12.0	0.8
1.5	190	G1	3	15	3	160	3.8	1.2	22.5 x 18.5 x 11.3	1.1
2.5	130	G1	5	25	5	200	5.6	1.8	15.5 x 13.5 x 12.0	0.8
2.5	190	G1	5	25	5	210	5.3	1.7	22.5 x 18.5 x 11.3	1.1

Tolerance of pressure loss: +/- 5%

Dimensions (q_p 0.6 – 2.5 m^3/h)

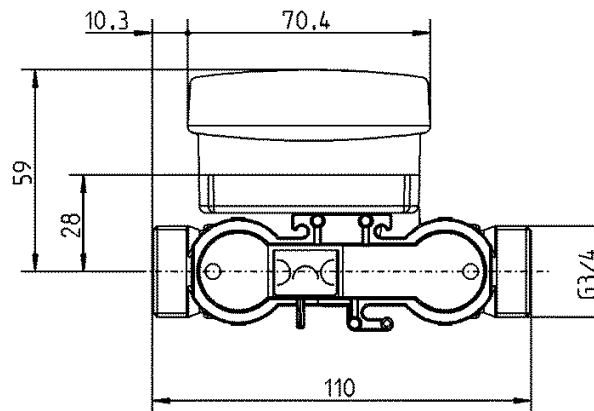

Fig. 1: Overview dimensions overall length 110 mm

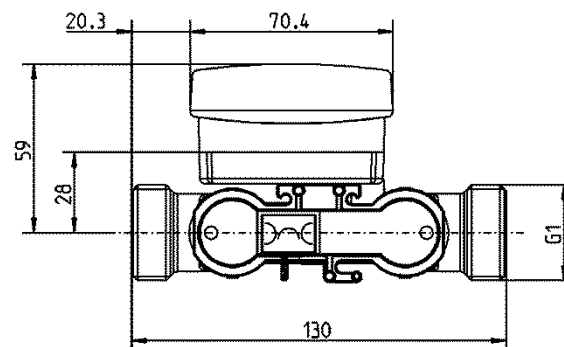

Fig. 2: Overview dimensions overall length 130 mm (thread)



Abb. 3: Overview dimensions overall length 190 mm (thread)



Order- No.	qp	PN	Overall length
	m ³ /h	bar	mm
UH30-x05	0.6	16	110
UH30-x06	0.6	25	110
UH30-x07	0.6	16	190
UH30-x09	0,6	25	190
UH30-x21	1.5	16	110
UH30-x22	1.5	25	110
UH30-x23	1.5	16	190
UH30-x25	1.5	25	190
UH30-x26	1.5	16	130
UH30-x27	1.5	25	130
UH30-x36	2.5	16	130
UH30-x37	2.5	25	130
UH30-x38	2.5	16	190
UH30-x40	2.5	25	190

4 Installation

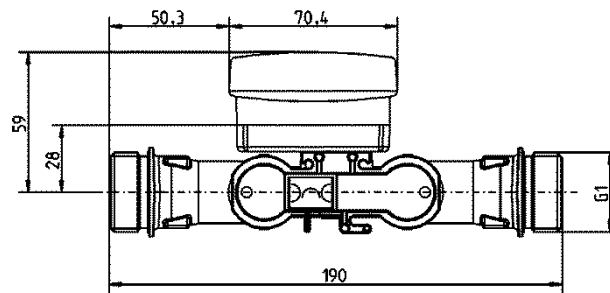

To install the meter proceed as follows:

- Determine the place of installation in line with the inscription on the meter.



Note: For a **heat meter** the mounting place of the cold side is equivalent to return  and the mounting place hot side is equivalent to flow .



Note: For a **cooling meter** the mounting place of the hot side is equivalent to return  and the mounting place of the cold side is equivalent to flow .

- Observe the dimensions of the meter and check whether there is sufficient space available.
- Rinse the system thoroughly before installing the meter.
- Fit the meter vertically or horizontally between two slide valves so that the arrow on the housing and the flow direction match. Also observe the installation situations and the following examples of installation.
- Fit the temperature sensors in the same circuit as the meter. Observe in addition the admixtures.
- Seal the temperature sensor and the fittings to protect against manipulation.
- If you install the meter for cooling metering, follow the respective notes.

Recommendation: If you are installing several meters, the same installation conditions must be consistent for all meters.

Installation notes



Note: Observe the local valid installation instructions mounting the meter.

Inlet or outlet sections are not necessary. If you install the meter in the common return of two circuits, determine a place of installation with a minimum distance of $10 \times \text{DN}$ from the T-piece. This distance ensures a good thorough mixing of the different water temperatures. You can install the temperature sensors in T-pieces, ball valves, directly immersed or in pockets depending on the version. The temperature sensor ends must reach to at least the middle of the pipe cross section.



Note: Protect the meter against damage through mechanical shocks or vibrations at the place of installation.



Note: Ensure the electronic unit is protected against any ingress of water.

Examples of installation

You can install the meter in any position e.g. vertically or horizontally. In order to avoid accumulation of air and disruption in operation, fit the meter in a vertical installation position and not in the uppermost area of a pipeline.

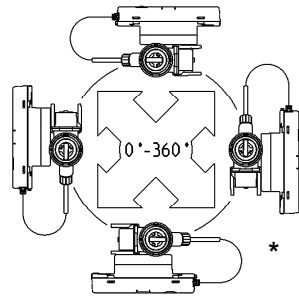

* This position is not permitted for cold meters and in cases where moisture can enter the electronic unit due to condensation (e.g. during an interruption in the summer).

Fig. 4: Mounting position

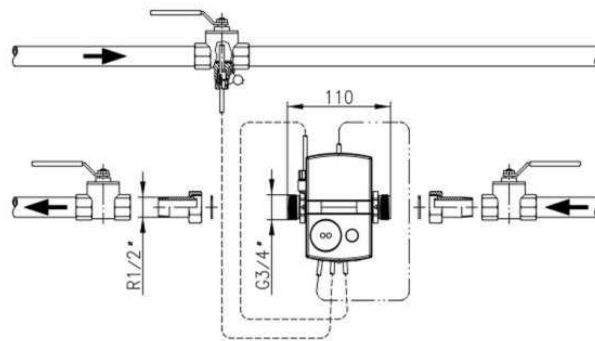

Fig. 5: Example for installation

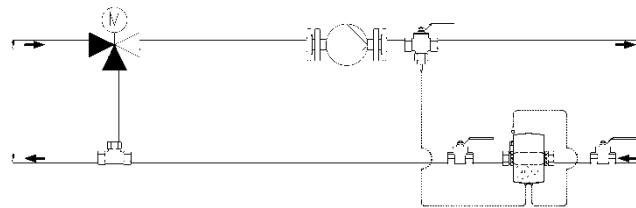

Fig. 6: Installation for circulation with admixing; placement of temperature sensors

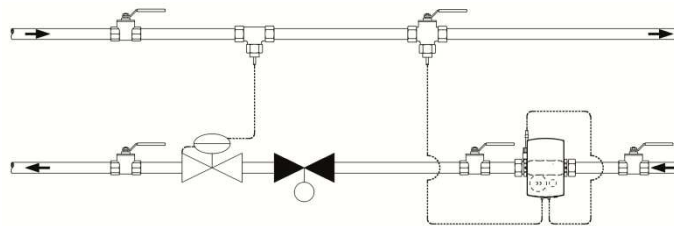

Fig. 7: Installation for circulation with throttling configuration (flow sensor in flow direction before control valve / differential pressure regulating valve)

Installation notes for sensor adapter set (sensors directly immersed)

A mounting set is included for meters with 5.2 × 45 mm temperature sensor. With this you can fit the temperature sensor directly immersed into an insert or a ball valve for example.

1. Install with O-ring at the point of installation with the fit-up aid/pen provided.
2. Place both halves of the plastic bolting round the 3 notches of the temperature sensor.
3. Press the bolting together and screw the bolting hand tight into the point of installation until it comes to a stop (tightening torque 3 ... 5 Nm).

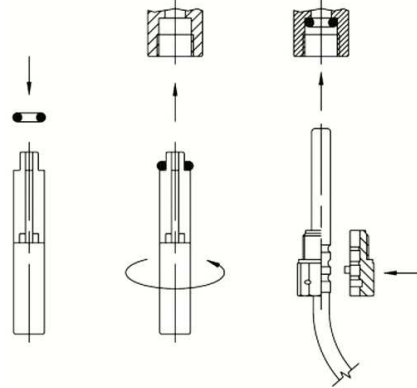

Fig. 8: Mounting adapter set

4.1 Installation for cooling metering

Observe the following installation instructions to avoid condensation:

- Mount the cooling meter so that the black covering on the measuring section points sideward or downwards.
- Mount the electronic unit separated from the volume measuring unit e. g. on the wall.
- Form with the connected cables a loop downwards.
- Mount the protection pocket so that the temperature sensor is oriented vertically downwards or horizontally.
- Mount the temperature sensor horizontally or vertically in the pipe from below.

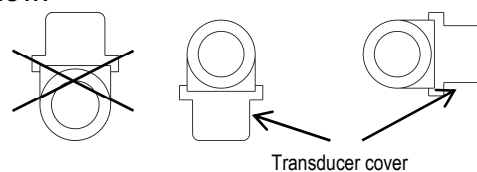

Fig. 9: Recommended installation orientation for cooling metering

5 Dimension of electronic unit

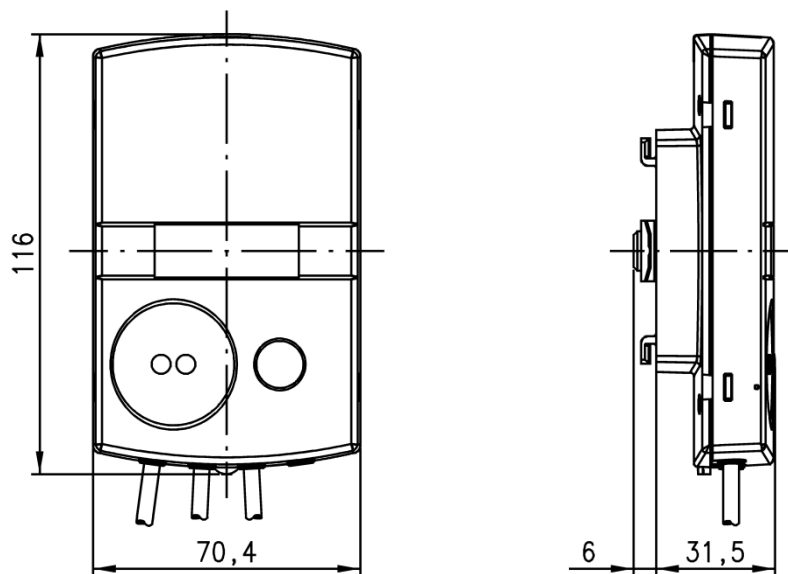

Fig. 10: Electronic unit

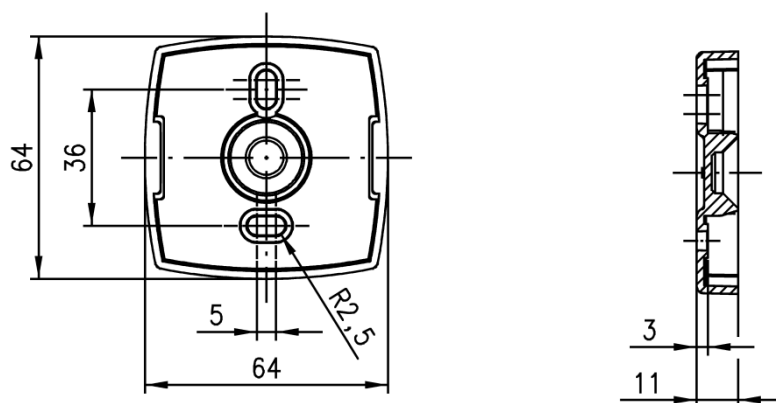

Fig. 11: Wall adapter (view from above and side)

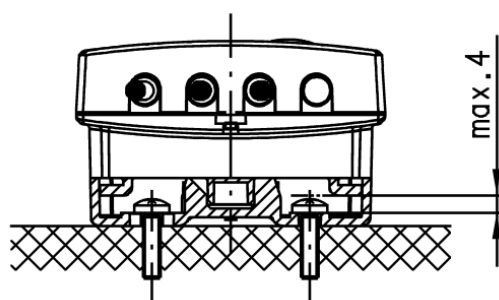

Fig. 12: Maximum screw head height (if using the wall bracket)

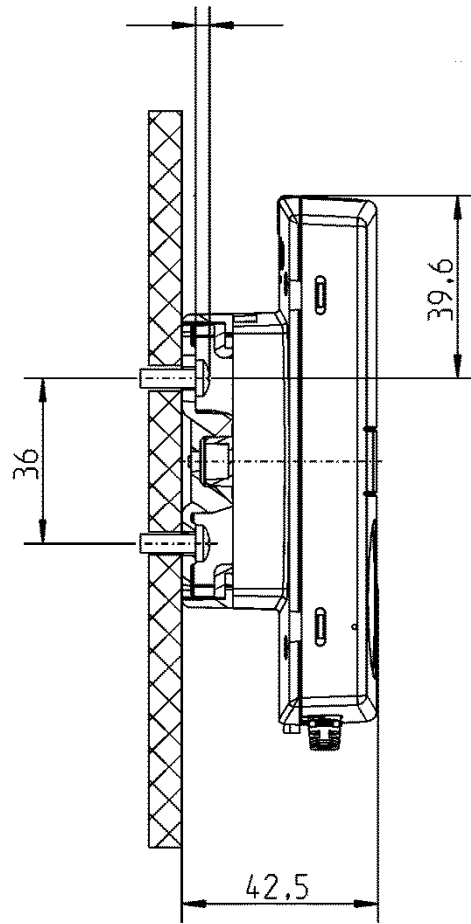

Fig. 13: Wall mounting

6 Operating elements

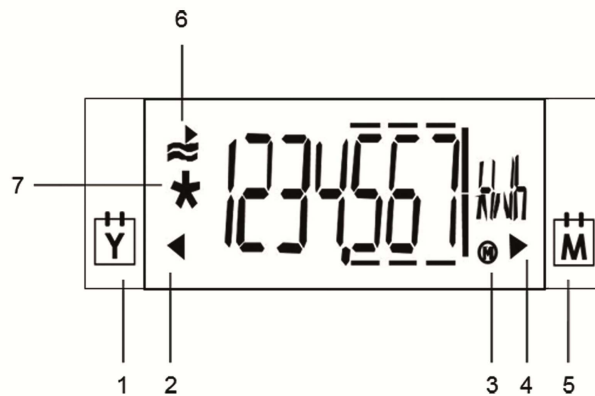





Fig. 14: LCD



No.	Description
1	Identification previous year value
2	Previous year value
3	Maxima
4	Previous month value
5	Identification previous month value
6	Activity display at flow
7	Calibrated value

6.1 Displaying current meter status

The meter displays the current meter status in kWh, MWh, MJ or GJ.

-  **Note:** In order to prevent reading errors, the decimal places of the values displayed are marked with a frame.
-  **Note:** Calibrated values can be recognized by an additionally displayed star symbol.
-  **Note:** Both display range and data displayed can differ from the description depending on the appliance parameterization. Certain button functions can also be blocked.

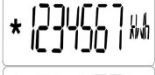
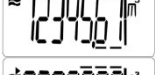
User loop “LOOP 0”

	User loop
	Energy quantity
	Volume
	Segment test
	In case of error: error code

Current values "LOOP 1"

LOOP 1	Current values
1234 m ³ /h	Current flow
3000 kW	Current heat power
670 °C	Current temperature hot side / cold side alternating in 2 s cycles
460 °C	
210 K	Temperature difference
bd 1234 h	Operating time
Fd 123 h	Missing time
Pd 1234 h	Time with flow

Previous month's values "LOOP 2"

LOOP 2	Monthly values
0102.12 M	Log date
1234567 kWh	Energy quantity and volume on set day
1234567 m ³	
Fd 123 h	Missing time on set day
3899 m ³ /h	Max. flow in 2 s cycles with date stamp
1701.12	
1000 kW	Max. power in 2 s cycles with date stamp
1701.12	
810 °C	Max. temperature hot side in 2 s cycles with date stamp
1702.12	
660 °C	Max. temperature cold side in 2 s cycles with date stamp
1702.12	

General / Communication “LOOP 3“

	General / Communication
	Device number, 7-digit
	Optional interface
	Primary address (only for M-Bus)
	Secondary address 7-digit - for M-Bus
	Yearly set day
	Monthly set day
	Firmware version
	CRC-Code

Other “LOOP 4“

	Other
	Date
	Time
	Code entry for test / para operation

6.2 Monthly values

The meter stores the following values for 24 months on the monthly set day

- Missing time
- Volume
- Energy

and maxima with date stamp for

- Flow
- Power
- Temperature hot side
- Temperature cold side

The monthly values can be read via optical interface.



Note: Central European Time (CET) applies as the standard time. During summer time the storage takes place at the corresponding times.

7 Resolution of the display

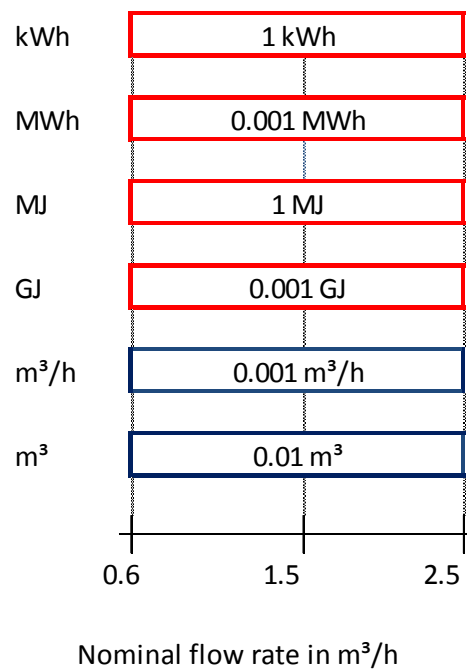

8 Power supply

The meter is according to the configuration equipped with 1 – 3 lithium batteries.

Options:

- 6 years battery
- 11 years battery

9 Communication

Electronic unit interfaces

The meter is equipped with an optical interface in accordance with EN 62056-21:2002 as standard.



Note: You can find further information in their respective documentation.

9.1 M-Bus

If the meter is equipped with the option M-Bus, it is supplied with a 2-wire cable which you can extend by fitting a junction box.

Standard	EN 13757-2 and -3
Reading interval	>1 min @ 2400 baud



Note: Frequent turning on and off of the M-Bus voltage can lead to reduction of battery lifetime.

9.2 Pulse output

The pulse output permits the transmission of energy or volume equivalent pulses.

Two channels are available. Their functions can be parameterized with the service software or can be adapted in the “Para menu” of the meter.

Available are standard pulses or high-definition pulses.

The pulse duration is identical for channel 1 and channel 2.

Cable labelling	passive pulse output
Cable	1.5 m; 4-wired, LL84201 4xAWG28 / 0.2 mm ²
Cable diameter	4 mm
Output type	open drain
Voltage	max. 30 V
Current	max. 30 mA
Dielectric strength	500 V _{eff} against ground
Classification	OB/OC (acc. to EN 1434-2)
ON/OFF resistance	<74 Ω / 6 MΩ
Output connection	

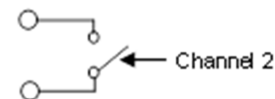
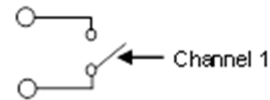

9.3 Wireless M-Bus

The wireless M-Bus function enables the meter to communicate with a stationary unit (e. g. radio concentrator, smartphone with radio adapter) using 868 MHz radio frequency (unlicensed).

The function supports the OMS¹⁾-compliant data transfer.

Standard	Open Metering System Specification (Issue 3.0.1); EN 13757-4
Frequency	868.95 MHz (min. 868.90 MHz to max. 869.00 MHz)
Transmission power	Min. 3.16 mW (5 dBm) to max. 25 mW (13.9 dBm)
Range ²⁾	
- Free field	Up to max. 400 m
Power supply	max. 3 batteries type AA
Sending interval	
- Mobile data reading	Acc. to configuration 20 – 34 sec
- Stationary data reading	15 min
- User defined data reading	Acc. to telegram length 12 – 900 sec

¹⁾ Open Metering System

²⁾ May vary depending on terrain and building structure

Predefined data telegrams



Note: Please tell us if encryption needs to be set at factory. The unique encryption key for every meter will be created and you will get a file by email (meter number <> encryption key).

Data telegram F000 – stationary radio (sending interval 15 min)

Following data are available by default for data reading:

- Current energy
- Current volume
- Current flowrate
- Current power
- Current temperature hot side
- Current temperature cold side
- Error (manufacturer specific)
- Current timestamp (type I)

Data telegram F001 – mobile data reading (sending interval 20 sec, battery life-time 6 years)

Following data are available by default for data reading:

- Current energy
- Current volume
- Energy: previous month on reference date
- Volume: previous month on reference date
- Monthly reference date
- Energy: previous year on reference date
- Annual set date
- Error (manufacturer specific)
- Current timestamp (type I)

Data telegram F002 – mobile data reading (sending interval 34 sec, battery life-time 11 years)

Following data are available by default for data reading:

- Current energy
 - Energy: previous month on set date
 - Monthly reference date
 - Energy: previous year on reference date
 - Annual reference date
 - Error (manufacturer specific)
 - Current timestamp (type I)
-

10 Error codes

The meter continuously runs a self-diagnosis and can thus recognize and display various installation or error messages.

Error code	Error	Service guidelines
FL nEG	Incorrect flow direction	Check flow or installation direction; correct if necessary
if necessary in exchange with:		
DIFF nEG	Negative temperature difference	Check installation point of the temperature sensors; exchange if necessary
if necessary in exchange with:		
F0	No flow can be measured	Air in the measurement unit/pipe; bleed air from line (delivery condition)
F1	Interruption in the hot side temperature sensor	Inform service department
F2	Interruption in the cold side temperature sensor	Inform service department
F3	Electronics for temperature evaluation defective	Inform service department
F4	Problem with the power supply; Battery flat	Inform service department
F5	Short-circuit hot side temperature sensor	Inform service department
F6	Short-circuit cold side temperature sensor	Inform service department
F7	Fault in internal memory holding	Inform service department
F8	F1, F2, F3, F5 or F6 for longer than 8 hours, recognition of attempts to manipulate. No further measurements are carried out.	Measure dependent on error code. Error message F8 must be reset by service department.
F9	Fault in the electronics	Inform service department



Note: Reset the message F8 in the parameterization mode manually or with the service software. All other error messages are deleted automatically once the error has been rectified.

11 Order codes (type number key)

Type code:

U H 3 0 - X X X X - X X X X - X - X X - X X - X X X

1. Meter type and mounting location
2. Nominal flowrate
3. Control cable / type / electronic unit
4. Country / where used
5. Manufacturer's label
6. Sensor type and connection method
7. Sensor design
8. Communication
9. Power supply
10. Calibration / conformity
11. Energy unit

Order codes for label plate data

1. Type of meter and mounting location	Code
Heat meter for mounting place cold side	A
Heat meter for mounting place hot side	B
Cooling meter for mounting place hot side	G
Cooling meter for mounting place cold side	H
2. Nominal flowrate	Code
Nominal flowrate 0.6 m ³ /h, length 110 mm, nominal pressure PN16, connection G ¾ B	05
Nominal flowrate 0.6 m ³ /h, length 110 mm, nominal pressure PN25, connection G ¾ B	06
Nominal flowrate 0.6 m ³ /h, length 190 mm, nominal pressure PN16, connection G 1 B	07
Nominal flowrate 0.6 m ³ /h, length 190 mm, nominal pressure PN25, connection G 1 B	09
Nominal flowrate 1.5 m ³ /h, length 110 mm, nominal pressure PN16, connection G ¾ B	21
Nominal flowrate 1.5 m ³ /h, length 110 mm, nominal pressure PN25, connection G ¾ B	22
Nominal flowrate 1.5 m ³ /h, length 190 mm, nominal pressure PN16, connection G 1 B	23
Nominal flowrate 1.5 m ³ /h, length 190 mm, nominal pressure PN25, connection G 1 B	25
Nominal flowrate 1.5 m ³ /h, length 130 mm, nominal pressure PN16, connection G 1 B	26
Nominal flowrate 1.5 m ³ /h, length 130 mm, nominal pressure PN25, connection G 1 B	27
Nominal flowrate 2.5 m ³ /h, length 130 mm, nominal pressure PN16, connection G 1 B	36
Nominal flowrate 2.5 m ³ /h, length 130 mm, nominal pressure PN25, connection G 1 B	37
Nominal flowrate 2.5 m ³ /h, length 190 mm, nominal pressure PN16, connection G 1 B	38
Nominal flowrate 2.5 m ³ /h, length 190 mm, nominal pressure PN25, connection G 1 B	40
3. Control cable / type / electronic unit	Code
Split version with 1.5 m control cable	C
4. Country	Code
Middle East (English)	AE
Austria (German)	AT
Belarus (Russian)	BY
Switzerland (German/French)	CH
Czech Republic (Czech)	CZ
Germany (German)	DE
Denmark (Danish)	DK
English neutral	EN
Spain (Spanish)	ES
Great Britain (English)	GB
Italy (Italian)	IT

Norway (Norwegian)	NO
Poland (Polish)	PL
Sweden (Swedish)	SE
Slovenia (Slovenian)	SI
5. Manufacturer's label	Code
Logo Landis+Gyr	00
Other labels on request	xx
6. Sensor type and method of connection	Code
Sensor Pt500, not mounted in the tube	N
Sensor Pt500, mounted in the tube	P
Hardware-dependent features	
7. Sensor type	Code
Type DS, 25 bar/ 105 °C/ M10x1, cable length 1,5 m	0B
Type PS, 16 bar/ 105 °C/ Ø5,2x45 mm, cable length 1,5 m	0H
Type PS, 16 bar/ 105 °C/ Ø5,2x45 mm, cable length 5 m	0J
8. Communication	
No module	0
M-Bus	B
wM-Bus 868 MHz stationary	E
wM-Bus 868 MHz mobile	F
Pulse	L
9. Power supply	Code
Battery for 6 years	A
Battery for 11 years	F
10. Calibration / conformity	Code
Compliant to national regulations	TL
Certified acc. to national regulations	CL
Compliant to MID, class 2	M2
Compliant to MID, class 3	M3
Compliant with CEN 1434 class 2	T2
Compliant with CEN 1434 class 3	T3
11. Energy unit	Code
Display: kWh	A
Display: MWh with 3 decimal places	B
Display: MJ	C
Display: GJ with 3 decimal places	D

*) Additional ordering information needed (see page 23)

12 Additional ordering information for wM-Bus



Note: The battery life time always depends on the meter configuration (measuring interval) and on the data telegram length, encryption (with / without) and sending interval (mobile / stationary)!

All these configurations can be changed with the service software!



Note: Data in the radio module is updated every 15 minutes independent of the sending interval.

Necessary additional ordering information's:

- You must decide for “stationary radio (sending interval 15 min.)” or “mobile data reading (sending interval 20 – 34 sec.)”.
- Please tell us if encryption needs to be set at factory.
- The unique encryption key for every meter will be created and you will get a file by electronic delivery note (meter number <> encryption key).

1. Stationary radio:

Ordering example battery life **6 years**, data telegram F000, sending interval 15 min.:

UH30-XXXX-XXXX-X-XX-~~EA~~-XXX + F000 + encryption

E = Wireless M-Bus function stationary

A = Battery lifetime **6 years**

F000 = Stationary radio

Encryption (AES 128) = Yes / No

Ordering example battery life **11 years**, data telegram F000, sending interval 15 min.:

UH30-XXXX-XXXX-X-XX-~~EF~~-XXX + F000 + encryption

E = Wireless M-Bus function stationary

F = Battery lifetime **11 years** F000 = stationary radio

Encryption (AES 128) = Yes / No

2. Mobile data reading “walk by”

Ordering example battery life **6 years**, data telegram F001, sending interval 20 sec.:

UH30-XXXX-XXXX-X-XX-~~FA~~-XXX + F001+ encryption

F = Wireless M-Bus function mobile

A = Battery lifetime **6 years**

F001 = Mobile data reading

Encryption (AES 128) = Yes / No

Ordering example battery life **11 years**, data telegram F002, sending interval 34 sec.:

UH30-XXXX-XXXX-X-XX-~~FF~~-XXX + F002+ encryption

F = Wireless M-Bus function mobile

F = Battery lifetime **11 years**

F002 = Mobile data reading

Encryption (AES 128) = Yes / No

13 Pressure loss

Nominal flowrate qp	Overall length	Connection	Pressure loss at qp	Kv-Factor at Δp 1 bar	Graph in diagram
m ³ /h	mm	G / DN	mbar	m ³ /h	
0.6	110, 190	G ³ / ₄	150	1.5	A
1.5	130, 190	G1	160	3.8	B
1.5	110	G ³ / ₄	150	3.9	C
2.5	190	G1	210	5.3	D
2.5	130	G1	200	5.6	E

The indicated pressure loss of a flow sensor is at nominal flowrate qp. With the Kv-Factor, which defines the flow rate at a pressure loss of 1 bar, the pressure loss at any given flow rate can be calculated:

$$\Delta p = 1 \text{ bar} \times \left(\frac{Q}{K_v} \right)^2$$

$\Delta p = \text{pressure loss in bar}$

$Q = \text{flowrate in m}^3/\text{h}$

$K_v = K_v - \text{Factor at } \Delta p = 1 \text{ bar}$

Alternatively, the value can be taken from the diagram.

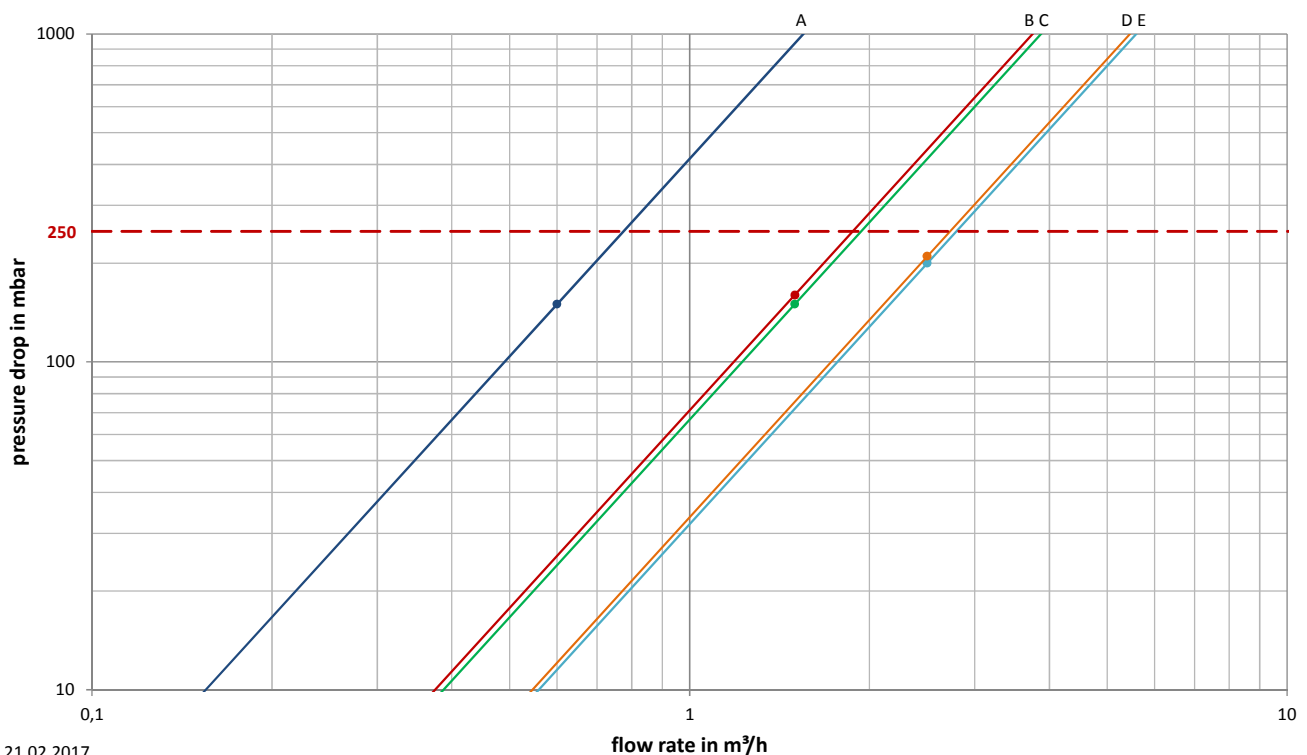

Landis+Gyr GmbH
Humboldtstrasse 64
90459 Nuremberg
Germany
